



# CC4067/CC4097

## DESCRIPTION

The **CC4067,CC4097** (extended temperature range) and **CC4067, CC4097** (intermediate temperature range) are monolithic integrated circuits available in 24-lead dual in line plastic or ceramic package.

The **CC4067** and **CC4097** COS/MOS analog multiplexers/demultiplexers are digitally controlled analog switches having low ON impedance, low OFF leakage current and internal

address decoding. in addition, the ON resistance is relatively constant over the full input-signal range.

The **CC4067** is a 16-channel multiplexer with four binary control inputs A, B, C, D, and an inhibit input, arranged so that any combination of the inputs selects one switch.

The **CC4097** is a differential 8-channel multiplexer having three binary control inputs A, B, C, and an inhibit input. The inputs permit selection of one

## FUNCTIONAL DIAGRAM

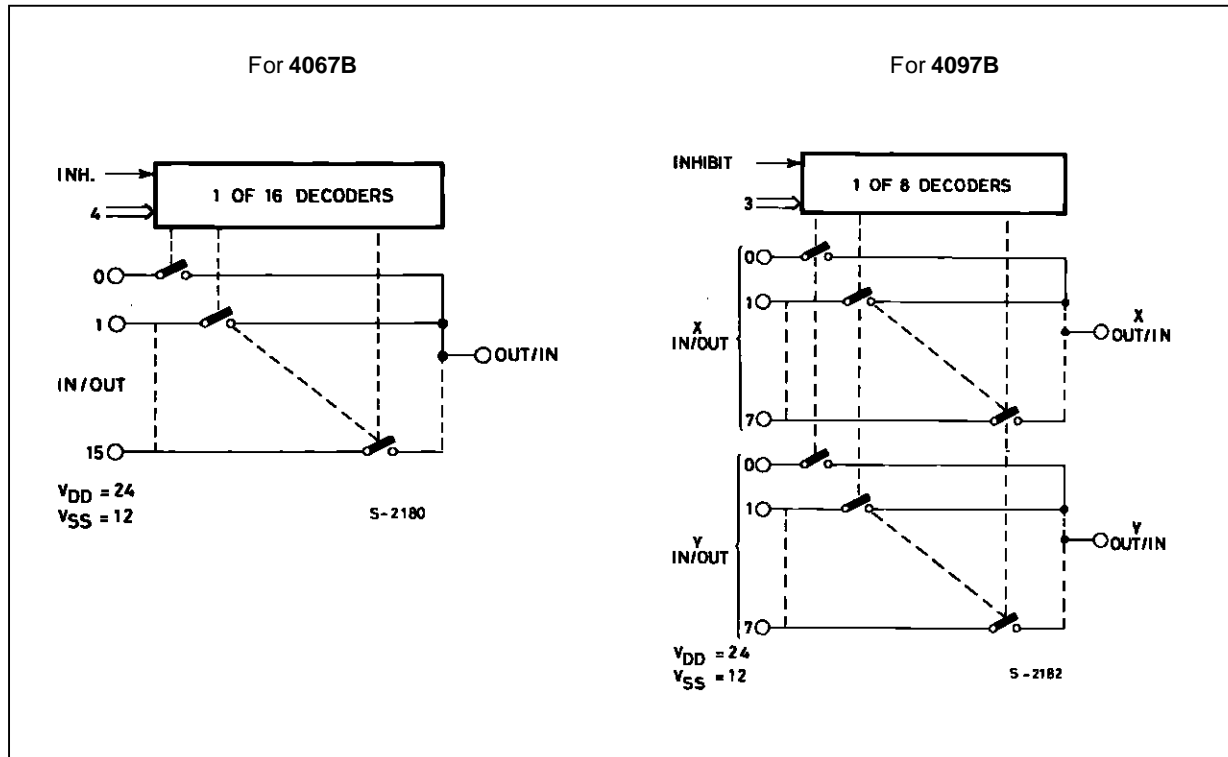

LOGIC DIAGRAM

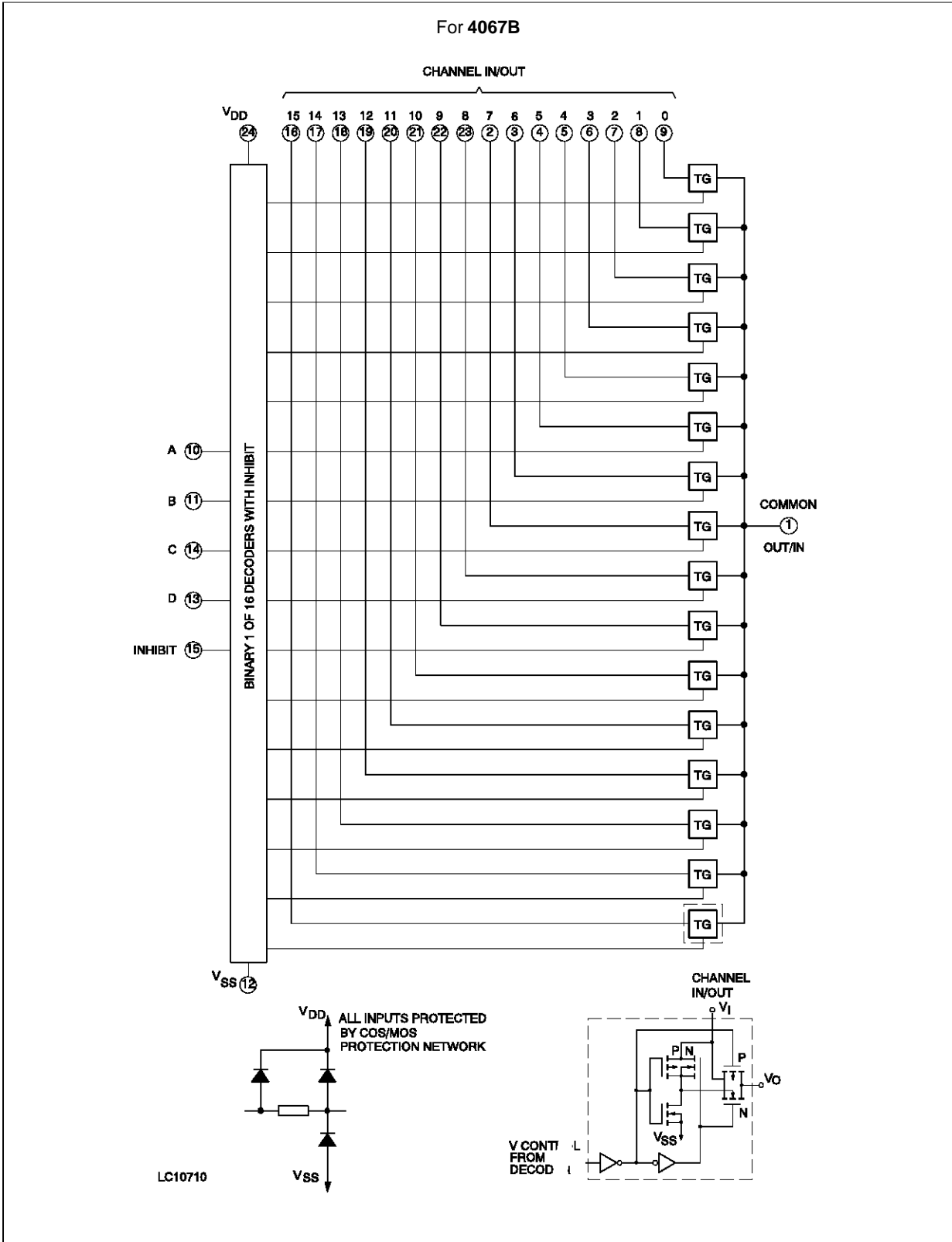

LOGIC DIAGRAM

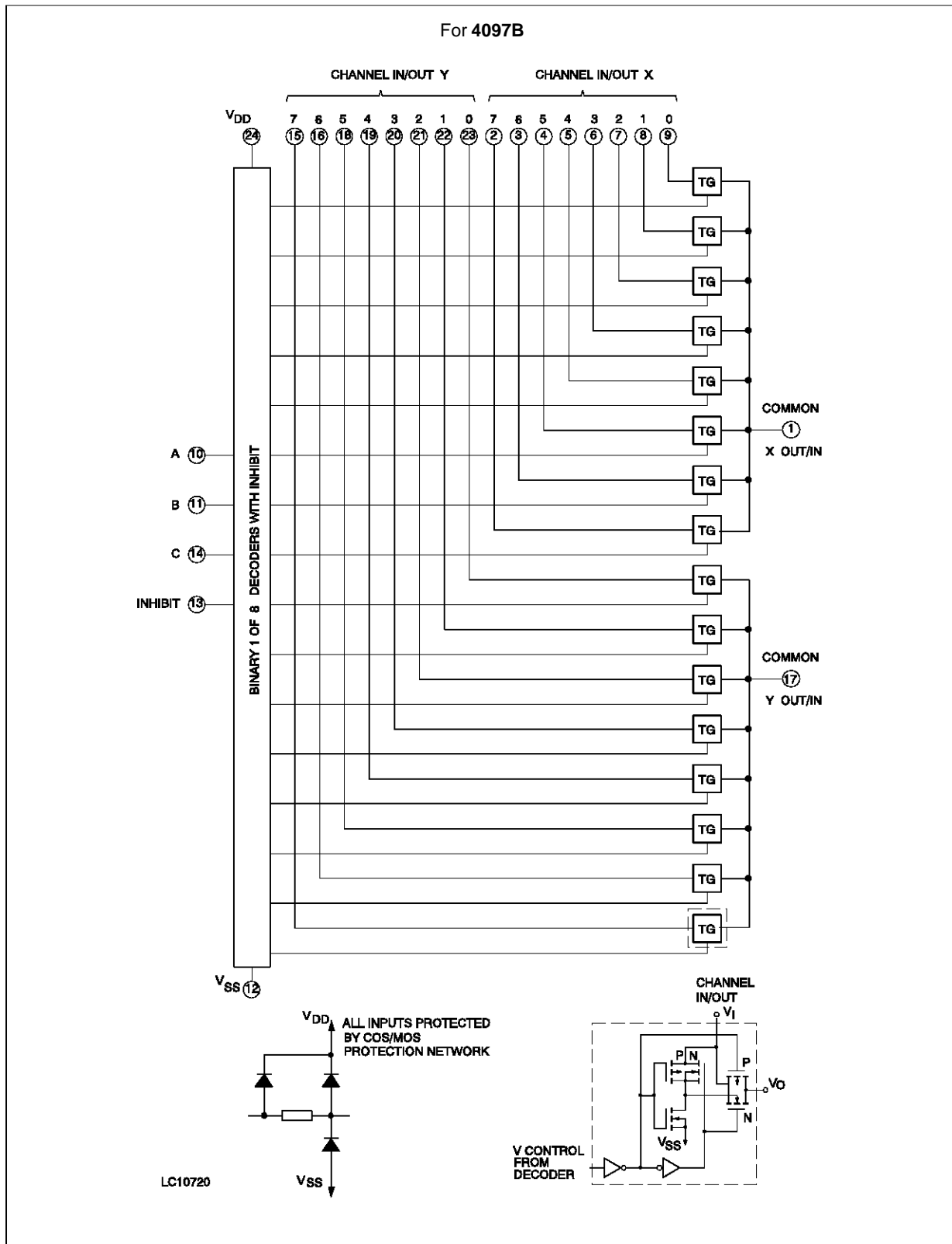

TRUTH TABLES FOR CC4067

A	B	C	D	INH	SELECTED CHANNEL
X	X	X	X	1	None
0	0	0	0	0	0
1	0	0	0	0	1
0	1	0	0	0	2
1	1	0	0	0	3
0	0	1	0	0	4
1	0	1	0	0	5
0	1	1	0	0	6
1	1	1	0	0	7
0	0	0	1	0	8
1	0	0	1	0	9
0	1	0	1	0	10
1	1	0	1	0	11
0	0	1	1	0	12
1	0	1	1	0	13
0	1	1	1	0	14
1	1	1	1	0	15

TRUTH TABLE FOR CC4097

A	B	C	INH	SELECTED CHANNEL
X	X	X	1	None
0	0	0	0	0X 0Y
1	0	0	0	1X 1Y
0	1	0	0	2X 2Y
1	1	0	0	3X 3Y
0	0	1	0	4X 4Y
1	0	1	0	5X 5Y
0	1	1	0	6X 6Y
1	1	1	0	7X 7Y

ABSOLUTE MAXIMUM RATING

Symbol	Parameter	Value	Unit
V <sub>DD</sub> *	Supply Voltage:	-0.5 to +20	V
V <sub>I</sub>	Input Voltage	-0.5 to V <sub>DD</sub> + 0.5	V
I <sub>I</sub>	DC Input Current (any one input)	± 10	mA
P <sub>tot</sub>	Total Power Dissipation (per package)	200	mW
	Dissipation per Output Transistor for Top = Full Package Temperature Range	100	mW
T <sub>op</sub>	Operating Temperature:	-55 to +125	°C
T <sub>stg</sub>	Storage Temperature	-65 to +150	°C

Stresses above those listed under "Absolute Maximum Ratings" may cause permanent damage to the device. This is a stress rating only and functional operation of the device at these or any other conditions above those indicated in the operational sections of this specification is not implied. Exposure to absolute maximum rating conditions for external periods may affect device reliability.

\* All voltage values are referred to V<sub>SS</sub> pin voltage.

RECOMMENDED OPERATING CONDITIONS

Symbol	Parameter	Value	Unit
V <sub>DD</sub>	Supply Voltage: HCC Types	3 to 18	V
V <sub>I</sub>	Input Voltage	0 to V <sub>DD</sub>	V
T <sub>op</sub>	Operating Temperature:		°C

**STATIC ELECTRICAL CHARACTERISTICS** (over recommended operating conditions)

Symbol	Parameter	Test Conditions				Value						Unit		
		V <sub>IS</sub> (V)	V <sub>EE</sub> (V)	V <sub>SS</sub> (V)	V <sub>DD</sub> (V)	T <sub>LOW</sub> *		25 °C			T <sub>HIGH</sub> *			
						Min.	Max.	Min.	Typ.	Max.	Min.		Max.	
I <sub>L</sub>	Quiescent Supply Current				5		5		0.04	5		150	μA	
					10		10		0.04	10		300		
					15		20		0.04	20		600		
					18		100		0.08	100		3000		
<b>SWITCH</b>														
R <sub>ON</sub>	On Resistance	HCC types	0 ≤ V <sub>I</sub> ≤ V <sub>DD</sub>	0	0	5		800		470	1050		1300	Ω
						10		310		180	400		580	
						15		200		125	240		320	
ΔON	Resistance ΔR <sub>ON</sub> (Between any two channels)					5				10			Ω	
						10				10				
						15				5				
OFF (●) Channel Leakage Current	Any Channel OFF			0	0	18		100		±0.1	100		1000	μA
				0	0	18		100		±0.1	100		1000	
C	Capacitance Input Output for 4067 Output for 4097 Feedthrough				-5	5				5			pF	
										55				
										35				
										0.2				
<b>CONTROL</b>														
V <sub>IL</sub>	Input Low Voltage	= V <sub>DD</sub> thru 1KΩ	V <sub>EE</sub> =V <sub>SS</sub> R <sub>L</sub> = 1KΩ to V <sub>SS</sub> I <sub>IS</sub> < 2μA (on all OFF channels)	5		1.5				1.5		1.5	V	
				10		3			3		3			
				15		4			4		4			
V <sub>IH</sub>	Input High Voltage			5	3.5		3.5				3.5	V		
				10	7		7				7			
				15	11		11				11			
I <sub>IH</sub> I <sub>IL</sub>	Input Leakage Current		V <sub>I</sub> = 0/18V	18		±0.1		±10 <sup>-3</sup>	±0.1		±1	μA		
C <sub>I</sub>	Input Capacitance		Any Address or Inhibit Input					5	7.5			pF		





• Determined by minimum feasible leakage measurement for automatic testing

\* T<sub>LOW</sub> = -55 °C for HCC device; -40 °C for HCF device.

\* T<sub>HIGH</sub> = +125 °C for HCC device; +85 °C for HCF device.

The Noise Margin for both "1" and "0" level is: 1V min. with V<sub>DD</sub> = 5V, 2V min. with V<sub>DD</sub> = 10V, 2.5V min. with V<sub>DD</sub> = 15V

**DYNAMIC ELECTRICAL CHARACTERISTICS** (T<sub>amb</sub> = 25 °C, C<sub>L</sub> = 50 pF, R<sub>L</sub> = 200 KΩ, typical temperature coefficient for all V<sub>DD</sub> values is 03 %/°C, all input rise and fall times= 20 ns)

Symbol	Parameter	Test Conditions						Value		Unit	
		V <sub>C</sub> (V)	R <sub>L</sub> (KΩ)	f <sub>i</sub> (KHz)	V <sub>I</sub> (V)	V <sub>SS</sub> (V)	V <sub>DD</sub> (V)	Typ.	Max.		
<b>SWITCH</b>											
t <sub>pd</sub>	Propagation Delay Time (Signal Input to Output)	= V <sub>DD</sub>	200			0	5 10 15		30 15 11	60 30 20	ns
	Frequency Response Channel "ON" (Sine Wave Input) at $20 \text{ Log } \frac{V_O}{V_I} = -3 \text{ dB}$	= V <sub>DD</sub>	1		5 (●)	0	10	V <sub>O</sub> at Common OUT/IN 4067B 4097B	14 20		ns
	Feedthrough (All Channels OFF) at $20 \text{ Log } \frac{V_O}{V_I} = -40 \text{ dB}$	= V <sub>SS</sub>	1		5 (●)	0	10	V <sub>O</sub> at Any Channel	60		MHz
	Frequency Signal Crosstalk at $20 \text{ Log } \frac{V_{O(B)}}{V_{I(A)}} = -40 \text{ dB}$	V <sub>C(A)</sub> =V <sub>DD</sub> V <sub>C(B)</sub> =V <sub>SS</sub>	1		5 (●)	0	10	Between Any two (A and B) Channels Between Sections (A and B) 4097B only	1 10 18		MHz
t <sub>w</sub>	Sine Wave Distortion (f <sub>is</sub> = 1KHz sine wave)	5 10 15	10	1	2 (●) 3 (●) 5 (●)	0	5 10 15		0.3 0.2 0.12		%
<b>CONTROL (address or Inhibit)</b>											
t <sub>PLH</sub> t <sub>PHL</sub>	Propagation Delay Time: Address or Inhibit to Signal OUT (Channel Turning ON)		1				0 0 0	5 10 15	325 135 95	650 270 190	ns
t <sub>PLH</sub> t <sub>PHL</sub>	Propagation Delay Time: Address or Inhibit to Signal OUT (Channel Turning OFF)		0.3				0 0 0	5 10 15	220 90 65	440 180 130	ns
	Address or Inhibit to Signal Crosstalk		10*				0	10	75		mV peak

(●) Peak to peak voltage symmetrical about  $\frac{V_{DD} - V_{SS}}{2}$

(\*) Both ends of channel