

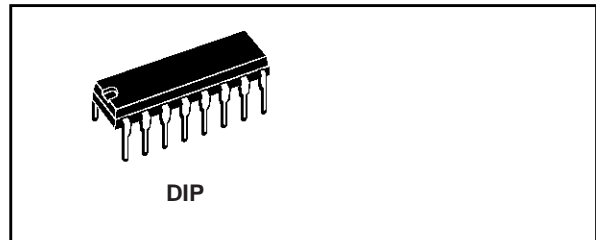

DUAL MONOSTABLE MULTIVIBRATOR

- RETRIGGERABLE/RESETTABLE CAPABILITY
- TRIGGER AND RESET PROPAGATION DELAYS INDEPENDENT OF  $R_X$ ,  $C_X$
- TRIGGERING FROM LEADING OR TRAILING EDGE
- Q AND  $\bar{Q}$  BUFFERED OUTPUT AVAILABLE
- SEPARATE RESETS
- WIDE RANGE OF OUTPUT PULSE WIDTHS
- QUIESCENT CURRENT SPECIFIED UP TO 20V
- 5V, 10V AND 15V PARAMETRIC RATINGS
- INPUT LEAKAGE CURRENT  
 $I_l = 100\text{nA (MAX) AT } V_{DD} = 18\text{V } T_A = 25^\circ\text{C}$
- 100% TESTED FOR QUIESCENT CURRENT
- MEETS ALL REQUIREMENTS OF JEDEC JESD13B "STANDARD SPECIFICATIONS FOR DESCRIPTION OF B SERIES CMOS DEVICES"



ORDER CODES

PACKAGE	TUBE	T & R
DIP	CC4098	

wide range of output pulse widths from the Q and  $\bar{Q}$  terminals. The time delay from trigger input to output transition (trigger propagation delay) and the time delay from reset input to output transition (reset propagation delay) and the time delay from reset input to output transition (reset propagation delay) are independent of  $R_X$  and  $C_X$ . Leading edge triggering (+TR) and trailing edge triggering (-TR) inputs are provided for triggering from either edge of an input pulse. An unused +TR input should be tied to  $V_{SS}$ . An unused -TR input should be tied to  $V_{DD}$ . A RESET (on low level) is provided for immediate termination of the output pulse or to prevent output pulses when power is turned on.

DESCRIPTION

The CC4098 is a monolithic integrated circuit fabricated in Metal Oxide Semiconductor technology available in DIP and SOP packages. The CC4098 dual precision monostable multivibrator provides stable retriggerable/resettable one-shot operation for any fixed voltage timing application. An external resistor ( $R_X$ ) and an external capacitor ( $C_X$ ) control the timing for the circuit. Adjustment of  $R_X$  and  $C_X$  provides a

PIN CONNECTION

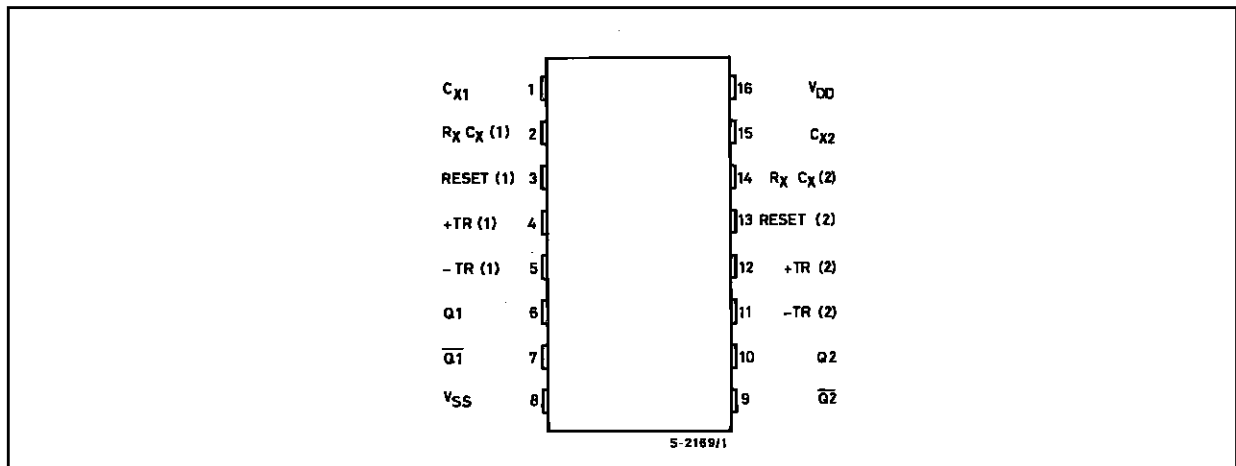

## CC4098

An unused RESET input should be tied to  $V_{DD}$ . However, if an entire section of the CC4098 is not used, its reset should be tied to  $V_{SS}$  (see table 1). In normal operation the circuit triggers (extends the output pulse one period) on the application of each new trigger pulse. For operation in the non-retiggerable mode,  $\overline{Q}$  is connected to -TR when leading edge triggering (+TR) is used or Q is connected to +TR when trailing edge triggering (-TR) is used. The time period (T) for this

### INPUT EQUIVALENT CIRCUIT

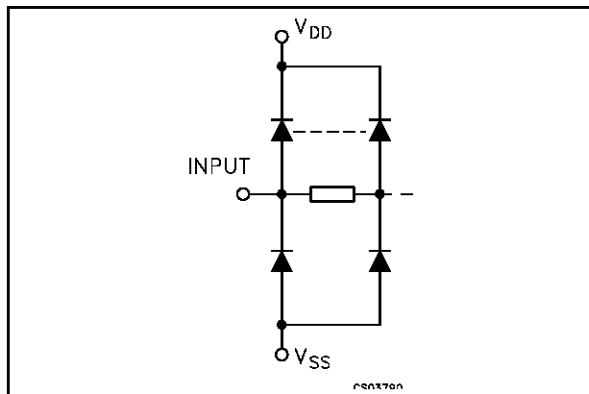

multivibrator can be calculated by:  $T = 1/2 R_X C_X$  for  $C_X \geq 0.01\mu\text{F}$ . The min. value of external resistance,  $R_X$ , is  $5\text{K}\Omega$ . The max. values of external capacitance,  $C_X$ , is  $100\mu\text{F}$ . The output pulse width has variations of  $\pm 2.5\%$  typically, over the temperature range of  $-55^\circ\text{C}$  to  $125^\circ\text{C}$  for  $C_X = 1000\text{pF}$  and  $R_X = 100\text{K}\Omega$ . For power supply variation of  $\pm 5\%$  typically, for  $V_{DD} = 10\text{V}$  and  $15\text{V}$  and  $\pm 1\%$  typically for  $V_{DD} = 5\text{V}$  at  $C_X = 1000\text{pF}$  and  $R_X = 5\text{K}\Omega$ .

### PIN DESCRIPTION

PIN No	SYMBOL	NAME AND FUNCTION
4, 12	+TR	Leading Trigger Inputs
5, 11	-TR	Trailing Trigger Inputs
3, 13	RESET	Reset Inputs
1, 15	$C_X1, C_X2$	External Capacitors
2, 14	$R_X C_X1$ $R_X C_X2$	External resistors to Vdd
6, 7	Q1, $\overline{Q1}$	Outputs Mono 1
10, 9	Q2, $\overline{Q2}$	Outputs Mono 2
8	$V_{SS}$	Negative Supply Voltage
16	$V_{DD}$	Positive Supply Voltage

### FUNCTIONAL DIAGRAM

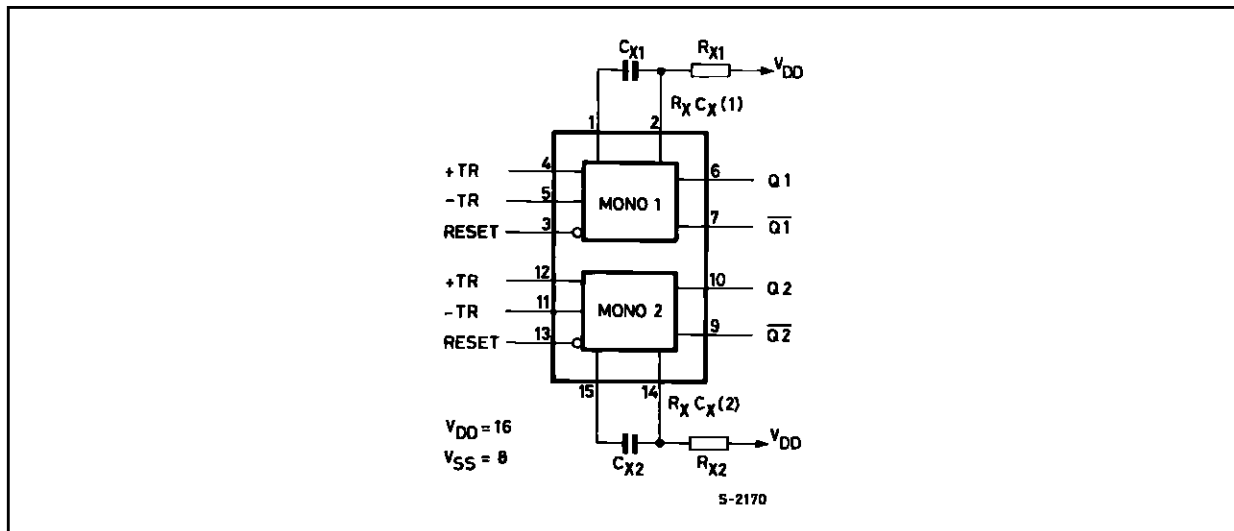

TABLE 1 : Functional Terminal Connections

FUNCTION	V <sub>DD</sub> to Term. N°		V <sub>SS</sub> to Term. N°		Input Pulse to Term. N°		Other Connections	
	Mono (1)	Mono (2)	Mono (1)	Mono (2)	Mono (1)	Mono (2)	Mono (1)	Mono (2)
Leading Edge Trigger/Retriggerable	3, 5	11, 13			4	12		
Leading Edge Trigger/Non Retriggerable	3	13			4	12	5, 7	11, 9
Trailing Edge Trigger/Retriggerable	3	13	4	12	5	11		
Trailing Edge Trigger/Non Retriggerable	3	13			5	11	4, 6	12, 10
Unused Section	5	11	3, 4	12, 13				

A Retriggerable one-shot multivibrator has an output pulse width which is extended on full time period (T) after application of the last trigger pulse.

A Non-Retriggerable one-shot multivibrator has a time period (T) referenced from the application of the first trigger pulse.

LOGIC DIAGRAM

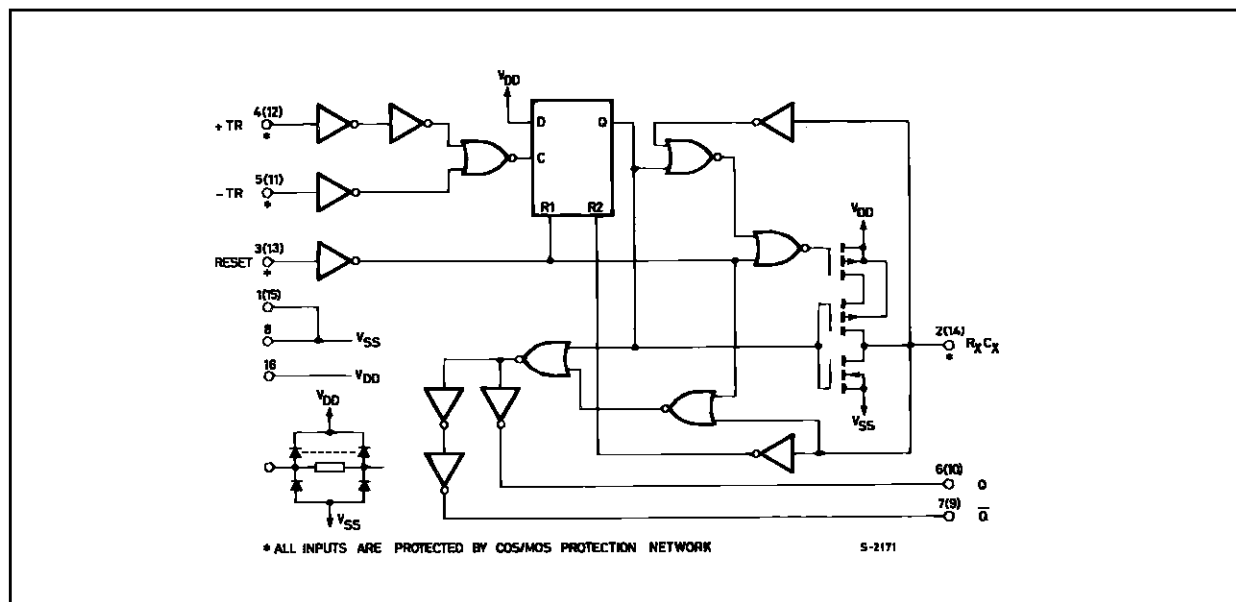

ABSOLUTE MAXIMUM RATINGS

Symbol	Parameter	Value	Unit
V <sub>DD</sub>	Supply Voltage	-0.5 to +20	V
V <sub>I</sub>	DC Input Voltage	-0.5 to V <sub>DD</sub> + 0.5	V
I <sub>I</sub>	DC Input Current	± 10	mA
P <sub>D</sub>	Power Dissipation per Package	200	mW
	Power Dissipation per Output Transistor	100	mW
T <sub>op</sub>	Operating Temperature	-55 to +125	°C
T <sub>stg</sub>	Storage Temperature	-65 to +150	°C

Absolute Maximum Ratings are those values beyond which damage to the device may occur. Functional operation under these conditions is not implied.

All voltage values are referred to V<sub>SS</sub> pin voltage.

## RECOMMENDED OPERATING CONDITIONS

Symbol	Parameter	Value	Unit
$V_{DD}$	Supply Voltage	3 to 18	V
$V_I$	Input Voltage	0 to $V_{DD}$	V
$T_{op}$	Operating Temperature	-55 to 125	°C

## DC SPECIFICATIONS

Symbol	Parameter	Test Condition				Value						Unit	
		$V_I$ (V)	$V_O$ (V)	$ I_{O} $ ( $\mu$ A)	$V_{DD}$ (V)	$T_A = 25^\circ\text{C}$			-40 to 85°C		-55 to 125°C		
						Min.	Typ.	Max.	Min.	Max.	Min.		Max.
$I_L$	Quiescent Current	0/5			5		0.02	1		30		30	$\mu$ A
		0/10			10		0.02	2		60		60	
		0/15			15		0.02	4		120		120	
		0/18			18		0.04	20		600		600	
$V_{OH}$	High Level Output Voltage	0/5		<1	5	4.95			4.95		4.95		V
		0/10		<1	10	9.95			9.95		9.95		
		0/15		<1	15	14.95			14.95		14.95		
$V_{OL}$	Low Level Output Voltage	5/0		<1	5		0.05			0.05		0.05	V
		10/0		<1	10		0.05			0.05		0.05	
		15/0		<1	15		0.05			0.05		0.05	
$V_{IH}$	High Level Input Voltage		0.5/4.5	<1	5	3.5			3.5		3.5		V
			1/9	<1	10	7			7		7		
			1.5/13.5	<1	15	11			11		11		
$V_{IL}$	Low Level Input Voltage		4.5/0.5	<1	5			1.5		1.5		1.5	V
			9/1	<1	10			3		3		3	
			13.5/1.5	<1	15			4		4		4	
$I_{OH}$	Output Drive Current	0/5	2.5	<1	5	-1.6	-3.2		-1.3		-1.3		mA
		0/5	4.6	<1	5	-0.51	-1		-0.42		-0.42		
		0/10	9.5	<1	10	-1.3	-2.6		-1.1		-1.1		
		0/15	13.5	<1	15	-3.4	-6.8		-2.8		-2.8		
$I_{OL}$	Output Sink Current	0/5	0.4	<1	5	-0.51	1		-0.42		-0.42		mA
		0/10	0.5	<1	10	-1.3	2.6		-1.1		-1.1		
		0/15	1.5	<1	15	-3.4	6.8		-2.8		-2.8		
$I_I$	Input Leakage Current	0/18	Any Input		18		$\pm 10^{-5}$	$\pm 0.1$		$\pm 1$		$\pm 1$	$\mu$ A
$C_I$	Input Capacitance		Any Input				5	7.5					pF

The Noise Margin for both "1" and "0" level is: 1V min. with  $V_{DD}=5V$ , 2V min. with  $V_{DD}=10V$ , 2.5V min. with  $V_{DD}=15V$

**DYNAMIC ELECTRICAL CHARACTERISTICS** ( $T_{amb} = 25^{\circ}\text{C}$ ,  $C_L = 50\text{pF}$ ,  $R_L = 200\text{K}\Omega$ ,  $t_r = t_f = 20\text{ ns}$ )

Symbol	Parameter	Test Condition			Value (*)			Unit
		$R_X$ (K $\Omega$ )	$C_X$ (pF)	$V_{DD}$ (V)	Min.	Typ.	Max.	
$t_{PLH}$ $t_{PHL}$	Propagation Delay Time +TR or -TR to Q or $\bar{Q}$	5 to 10000	$\geq 15$	5		250	500	ns
				10		125	250	
				15		100	200	
$t_{WH}$ $t_{WL}$	Trigger Pulse Width	5 to 10000	$\geq 15$	5	140	70		ns
				10	60	30		
				15	40	20		
$t_{TLH}$	Transition Time	5 to 10000	$\geq 15$	5		100	200	ns
				10		50	100	
				15		40	80	
$t_{THL}$	Transition Time	5 to 10000	15 to 10000	5		100	200	ns
				10		50	100	
				15		40	80	
		5 to 10000	0.01 $\mu\text{F}$ to 0.1 $\mu\text{F}$	5		150	300	
				10		75	150	
				15		65	130	
		5 to 10000	0.1 $\mu\text{F}$ to 1 $\mu\text{F}$	5		250	500	
				10		150	300	
				15		80	160	
$t_{PLH}$ $t_{PHL}$	Propagation Delay Time (Reset)	5 to 10000	$\geq 15$	5		225	450	ns
				10		125	250	
				15		75	150	
$t_{WR}$	Pulse Width (reset)	100	15	5	200	100		ns
				10	80	40		
				15	60	30		
			1000	5	1200	600		
				10	600	300		
				15	500	250		
		0.1 $\mu\text{F}$	5	50	250		$\mu\text{s}$	
			10	30	15			
			15	20	10			
$t_r$ , $t_f$ (TR)	Rise or Fall Time (trigger)		5 to 15				100	$\mu\text{s}$
	Pulse Width Match Between Circuits in Same Package	10	10000	5		5	10	%
				10		7.5	15	
				15		7.5	15	

 (\*) Typical temperature coefficient for all  $V_{DD}$  value is 0.3 %/ $^{\circ}\text{C}$ .