

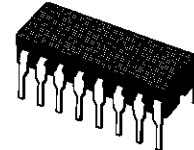

8-BIT ADDRESSABLE LATCH

- SERIAL DATA INPUT - ACTIVE PARALLEL OUTPUT
- STORAGE REGISTER CAPABILITY - MASTER CLEAR
- CAN FUNCTION AS DEMULTIPLEXER
- STANDARDIZED SYMMETRICAL OUTPUT CHARACTERISTICS
- QUIESCENT CURRENT SPECIFIED TO 20V FOR HCC DEVICE
- 5V, 10V, AND 15V PARAMETRIC RATINGS
- INPUT CURRENT OF 100nA AT 18V AND 25°C FOR HCC DEVICE
- 100% TESTED FOR QUIESCENT CURRENT
- MEETS ALL REQUIREMENTS OF JEDEC TENTATIVE STANDARD N°. 13A, "STANDARD SPECIFICATIONS FOR DESCRIPTION OF "B" SERIES CMOS DEVICES"



DESCRIPTION

The **CC4099** (extended temperature range) and **CC4099** (intermediate temperature range) are monolithic integrated circuits, available in 16-lead dual in-line plastic or ceramic package and plastic micro package. The CC4099 8-bit addressable latch is a serial-input, parallel-output storage register that can perform a variety of functions. Data are inputted to a particular bit in the latch when that bit is addressed (by means of inputs A0, A1, A2) and when WRITE DISABLE is at a low level. When WRITE DISABLE is high, data entry is inhibited ; however, all 8 outputs can be continuously read independent of WRITE DISABLE and address inputs. A master RESET input is available, which resets all bits to a logic "0" level when RESET and WRITE DISABLE are at a high level. When RESET is at a high level, and WRITE DISABLE is at a low level, the latch acts as a 1-of-8 demultiplexer ; the bit that is addressed has an active output which follows the data input, while all unaddressed bits are held to a logic "0" level.

PIN CONNECTIONS

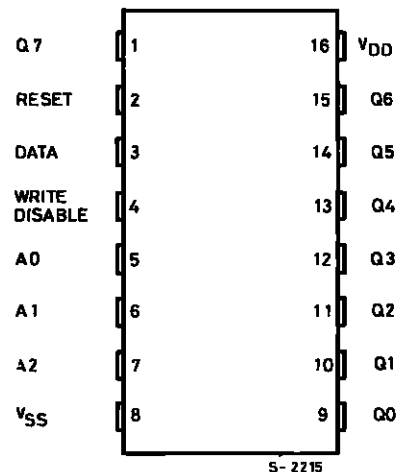

FUNCTIONAL DIAGRAM

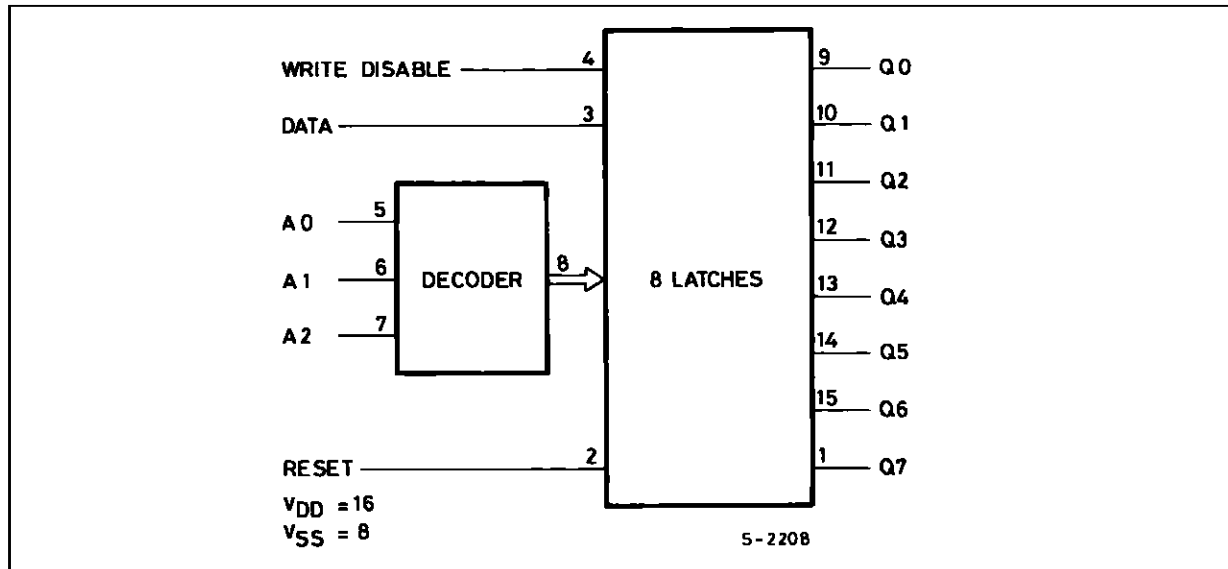

ABSOLUTE MAXIMUM RATINGS

Symbol	Parameter	Value	Unit
V_{DD}		- 0.5 to + 20	V
V_i	Input Voltage	- 0.5 to $V_{DD} + 0.5$	V
I_i	DC Input Current (any one input)	± 10	mA
P_{tot}	Total Power Dissipation (per package)	200	mW
	Dissipation per Output Transistor for T_{op} = Full Package-temperature Range	100	mW
T_{op}	Operating Temperature :	- 55 to + 125	$^{\circ}C$
T_{stg}	Storage Temperature	- 65 to + 150	$^{\circ}C$

Stresses above listed under "Absolute Maximum Ratings" may cause permanent damage to the device. This is a stress rating only and functional operation of the device at these or any other conditions above those indicated in the operational sections of this specification is not implied. Exposure to absolute maximum rating conditions for external periods may affect device reliability.

* All voltage values are referred to V_{SS} pin voltage.

RECOMMENDED OPERATING CONDITIONS

Symbol	Parameter	Value	Unit
V_{DD}	Supply Voltage :	3 to 18	V
V_i	Input Voltage	0 to V_{DD}	V
T_{op}	Operating Temperature :	- 55 to + 125	$^{\circ}C$

LOGIC DIAGRAM

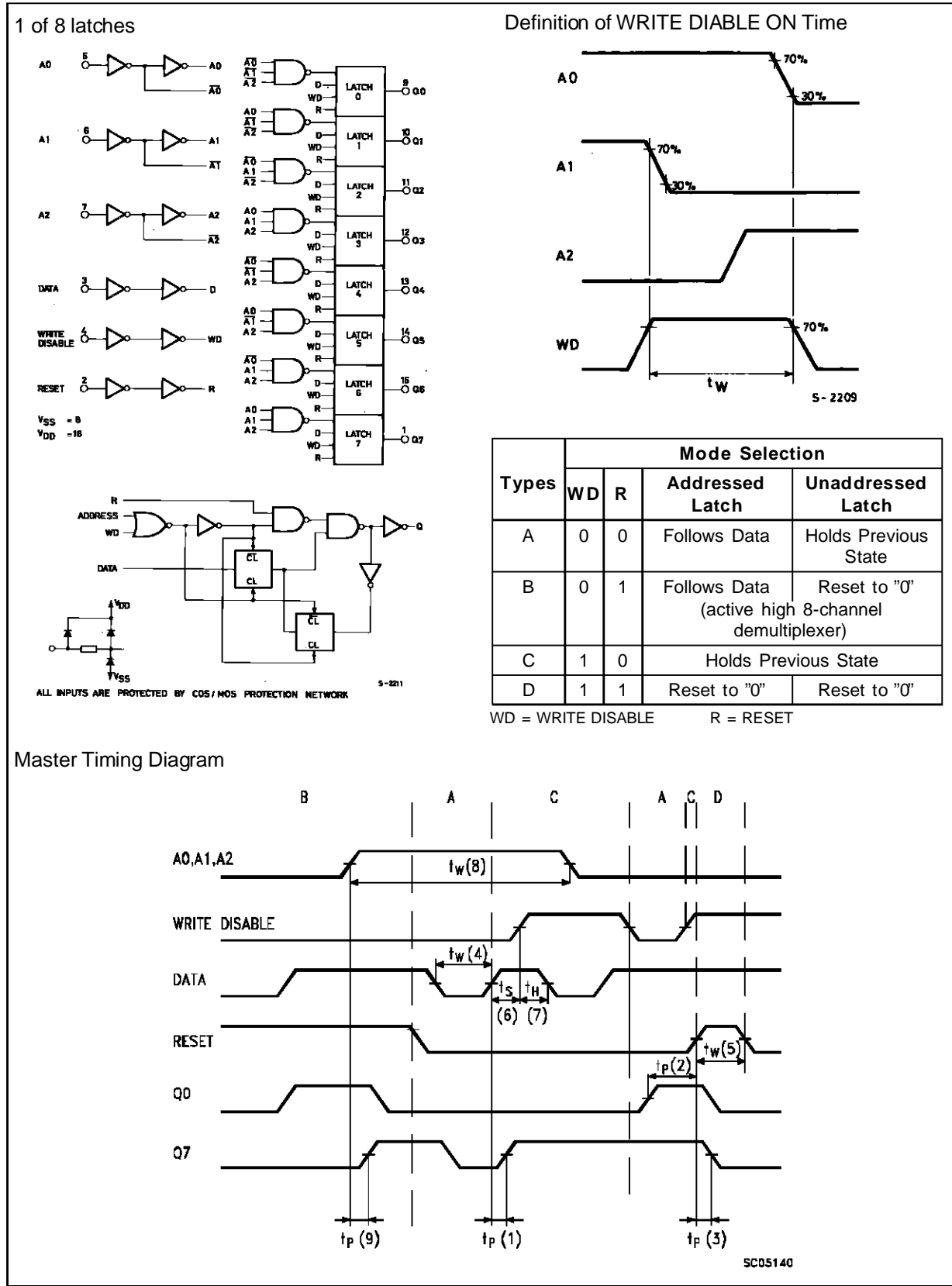

STATIC ELECTRICAL CHARACTERISTICS (over recommended operating conditions)

Symbol	Parameter		Test Conditions				Value						Unit	
			V _I (V)	V _O (V)	I _O (μ A)	V _{DD} (V)	T _{Low} *		25°C			T _{High} *		
							Min.	Max.	Min.	Typ.	Max.	Min.		Max.
I _L	Quiescent Current	HCC Types	0/ 5			5		5		0.04	5		150	μ A
			0/10			10		10		0.04	10		300	
			0/15			15		20		0.04	20		600	
			0/18			18		100		0.08	100		3000	
V _{OH}	Output High Voltage		0/ 5		< 1	5	4.95		4.95		4.95		V	
			0/10		< 1	10	9.95		9.95		9.95			
			0/15		< 1	15	14.95		14.95		14.95			
V _{OL}	Output Low Voltage		5/0		< 1	5		0.05		0.05		0.05	V	
			10/0		< 1	10		0.05		0.05		0.05		
			15/0		< 1	15		0.05		0.05		0.05		
V _{IH}	Input High Voltage			0.5/4.5	< 1	5	3.5		3.5		3.5		V	
				1/9	< 1	10	7		7		7			
				1.5/13.5	< 1	15	11		11		11			
V _{IL}	Input Low Voltage			4.5/0.5	< 1	5		1.5		1.5		1.5	V	
				9/1	< 1	10		3		3		3		
				13.5/1.5	< 1	15		4		4		4		
I _{OH}	Output Drive Current		0/ 5	2.5		5	- 2		- 1.6	- 3.2		- 1.15	mA	
			0/ 5	4.6		5	- 0.64		- 0.51	- 1		- 0.36		
			0/10	9.5		10	- 1.6		- 1.3	- 2.6		- 0.9		
			0/15	13.5		15	- 4.2		- 3.4	- 6.8		- 2.4		
I _{OL}	Output Sink Current		0/ 5	0.4		5	0.64		0.51	1		0.36	mA	
			0/10	0.5		10	1.6		1.3	2.6		0.9		
			0/15	1.5		15	4.2		3.4	6.8		2.4		
I _{IH} , I _{IL}	Input Leakage Current		0/18	Any Input		18		\pm 0.1		\pm 10 ⁻⁵	\pm 0.1		\pm 1	μ A
C _I	Input Capacitance			Any Input					5	7.5			pF	

DYNAMIC ELECTRICAL CHARACTERISTICS ($T_{amb} = 25^{\circ}\text{C}$, $C_L = 50\text{pF}$, $R_L = 200\text{k}\Omega$, typical temperature coefficient for all V_{DD} values is $0.3\%/^{\circ}\text{C}$, all input rise and fall times = 20ns)

Symbol	Parameter		Test Conditions (see master timing diagram)	Value			Unit	
				V_{DD} (V)	Min.	Typ.		Max.
t_{PLH}, t_{PHL}	Propagation Delay Time	Data to Output	(1)	5		200	400	ns
				10		75	150	
				15		50	100	
		Write Disable to Output	(2)	5		200	400	
				10		80	160	
				15		60	120	
		Address to Output	(9)	5		225	450	
				10		100	200	
				15		75	150	
t_{PHL}	Propagation Delay Time	Reset to Output	(3)	5		175	350	
				10		80	160	
				15		65	130	
t_{THL}, t_{TLH}	Transition Time	Any Output		5		100	200	ns
				10		50	100	
				15		40	80	
t_w	Pulse Width	Data	(4)	5	200	100		ns
				10	100	50		
				15	80	40		
		Address	(8)	5	400	200		
				10	200	100		
				15	125	65		
		Reset	(5)	5	150	75		
				10	75	40		
				15	50	25		
t_{setup}	Setup Time	Data to Write Disable	(6)	5	100	50		ns
				10	50	25		
				15	35	20		
t_{hold}	Hold Time	Data to Write Disable	(7)	5	150	75		ns
				10	75	40		
				15	50	25		